

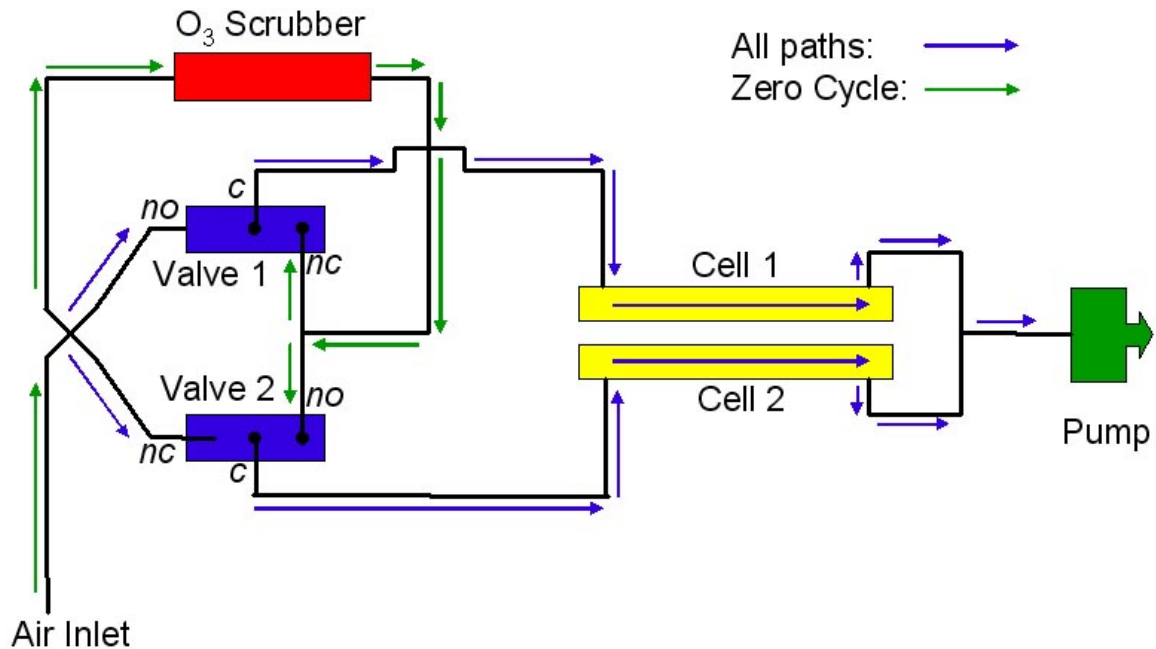

The Model 205 Ozone Monitor makes use of two detection cells to improve precision, baseline stability and response time. In the Dual Beam instrument, UV light intensity measurements I_0 (ozone-scrubbed air) and I (unscrubbed air) are made simultaneously. Combined with other improvements, this made it possible to reduce the time between ozone measurements to 2 seconds, making our instrument the fastest UV-based ozone monitor on the market, while still retaining the small size, weight and power requirements of our popular Model 202 Ozone Monitor. Fast measurements are especially desirable for aircraft and balloon measurements where high spatial resolution is desired. Alternatively, one can choose to average more points internally to obtain even better precision.

The Model 205 has all of the features of the Model 202, including choice of averaging time (2 s, 10 s, 1 min, 5 min, 1 hr), analog output (0-2.5 V), real time serial output, internal data logger with 3 analog inputs for simultaneous logging of other measurements (e.g., T, P and RH), real time clock, and optional flash memory.

Schematic Diagram



Features

- Backup sampling pump and flow meter (now standard); if the flow rate drops below a critical value, the backup pump is activated and an indication displayed on the LCD
- Internal data logger (EEPROM), logs 14,336 lines of data
- Real time clock
- Both serial and user-scaleable analog voltage outputs (5-20 mA current output optional)
- Three 0-2.5 VDC analog inputs for logging other measurements, such as external temperature, pressure and humidity
- Convenient user interface to microprocessor, including calibration parameters (gain and zero)
- Selectable data averaging times of 10 s, 1 min, 5 min and 1 hr (custom averaging times available)
- DewLine™ for elimination of any water vapor interference, a unique feature of 2B Tech instruments

Options

- Flash Card Memory for virtually unlimited, portable data storage
- GPS for continuous logging of latitude, longitude and altitude
- Rechargeable metal hydride battery provides 12 hr of continuous operation
- External particle filter

- Serial-to-USB adapter
- Rotary vane air pump for low temperature and quiet operation
- External air pump for long pump life

Specifications

Measurement Principle	UV Absorption at 254 nm; Dual Beam
Linear Dynamic Range	1.0 ppb to 250 ppm
Resolution	0.1 ppb
Precision (1σ; rms noise)	Greater of 1.0 ppb or 2% of reading
Accuracy	Greater of 1.0 ppb or 2% of reading
Limit of Detection (2σ)	2.0 ppb
NIST-Traceable Calibration	Yes
Measurement Interval	2 s (Data averaging options: 2 s; 10 s, 1 min, 5 min, 1 hr)
Flow Rate (nominal)	~1.8 Liter/min
Flow Rate Requirement	>1.2 L/min
Baseline Drift	<1 ppb/day <3 ppb/year
Sensitivity Drift	<1%/day <3%/year
Measurement Time, Frequency	2 s, 0.5 Hz
Response Time, 100% of Step Change	4 s, 2 points
Averaging Times	2 s, 10 s, 1 min, 5 min, 1 hr
Data Storage	14,336 lines (10 s avg. = 1.4 days; 5 min avg = 1.4 mo.)
Ozone Units	ppb, ppm, pphm, mg m ⁻³ , μ g m ⁻³
Pressure Units	mbar, torr

Temperature Units	°C, K
T and P Corrected	Yes
Operating Temperature Range	0 to 50 °C; -20 to 50 °C with low temperature modifications (rotary vane pump and lamp heater)
Operating Altitude Range	~0-30 km (~30-1000 mbar)
Power Requirement; Supplied by battery or 110/220 VAC Power Pack	12 V dc or 120/240 V ac, 415 mA, 5.0 watt (3.9 watt with cell heater unplugged)
Size	3.5 x 8.5 x 11 inches (9 x 21 x 29 cm)
Weight	4.7 lb (2.1 kg); 1.6 lb (0.7 kg) without instrument case
Data Logger Capacity	14,336 lines (10 s avg. = 1.4 days; 1 min avg = 10 days; 5 min avg = 1.4 mo; 1 hr avg = 1.6 yr)
Analog Inputs for Internal Logging of Other Instruments	3 Analog Inputs, 0-2.5 V; For example, could log external T, P and RH
Data Outputs	RS232, 0-2.5 V Analog, LCD Display; External USB Converter: (Optional 4-20 mA Current; request quote)
Data Transfer Baud Rates	1200, 2400, 4800, 19200
Output Ranges	User Defined Scaling Factor in Menu
DewLine™	Yes
Backup Air Pump	Yes
Flow Meter	Yes
Options	GPS, Flash Card Memory, 4-20 mA Current Output; Lamp Heater; Rotary Vane Air Pump; Long-Life External Air Pump; Rack Mount Case

System Includes

- Model 205 Ozone Monitor
- AC Power Adapter (100-240 VAC to 12 VDC) with Country-Specific Plug
- Cigarette Lighter Adapter
- Battery Wire Connector
- Zeroing Cartridge
- Operation Manual on CD
- Calibration Data and NIST-Traceable Calibration Certificate
- Instrument Birth Certificate
- One Year Warranty